

Alicates para teléfono

DIN ISO 5745

29

- > Superficie de agarre con dentado cruzado
- > Acero eléctrico al cromo vanadio, forjado, templado al aceite

29 21 160 / 29 25 160

Puntas finas especialmente delgadas, también adecuadas para trabajos de soldadura

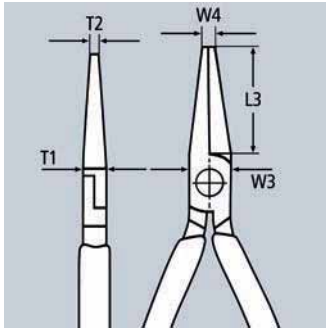

29 11 160



29 25 160



Núm. de artículo	EAN 4003773-	↔ mm		Alicate	Cabeza	Mangos	Dimensiones					g
							L3 mm	W3 mm	T1 mm	W4 mm	T2 mm	
29 11 160	016175	160		negro atramentado	pulida	recubiertos de plástico	55,0	14,0	8,0	2,5	8,5	103
29 21 160	043454	160		negro atramentado	pulida	recubiertos de plástico	54,0	14,0	9,0	2,0	2,0	112
29 25 160	043478	160		cromado		con fundas en dos componentes	54,0	14,0	9,0	2,0	2,0	139

Alicates de presión

(alicates con punta de aguja)

DIN ISO 5743

31

- > Alicates de precisión para trabajos de ensamblaje, doblado y ajuste
- > Bocas extra largas de 55,0 mm
- > Superficie de agarre lisa
- > Cantos sin rebabas
- > Acero eléctrico al cromo vanadio, forjado, templado al aceite

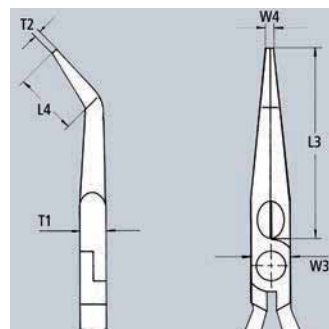
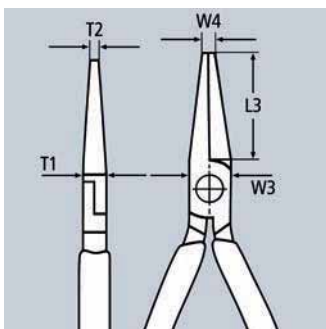

31 11 160



31 25 160

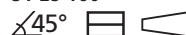

Núm. de artículo	EAN 4003773-	↔ mm		Alicate	Cabeza	Mangos	Dimensiones					g	
							L3 mm	L4 mm	W3 mm	T1 mm	W4 mm		T2 mm
31 11 160	044475	160		negro atramentado	pulida	recubiertos de plástico	55,0		16,0	7,5	1,8	2,5	100
31 15 160	016465	160		cromado		con fundas en dos componentes	55,0		16,0	7,5	1,8	2,5	124
31 21 160	046790	160		negro atramentado	pulida	recubiertos de plástico	55,0	27,0	16,0	7,5	1,8	2,5	97
31 25 160	016489	160		cromado		con fundas en dos componentes	55,0	27,0	16,0	7,5	1,8	2,5	123