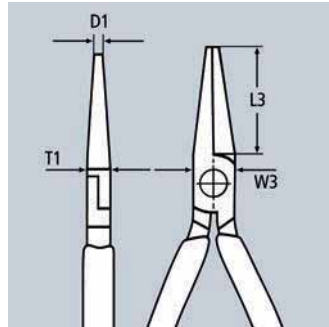

Alicates de boca redonda

DIN ISO 5745

22

- > Para formar aros de alambre
- > Mordazas redondas, cortas; con rectificado fino
- > Acero especial para herramientas, forjado, templado al aceite
- > puntas lisas

22 01 160
8 22 02 160
8 22 06 160

Núm. de artículo	EAN 4003773-	↔ mm		Alicate	Cabeza	Mangos	Dimensiones				
							L3 mm	W3 mm	D1 mm	T1 mm	g
22 01 125	014461	125					27,0	14,5	2,0	8,0	75
22 01 140	013013	140		negro atramentado	pulida	recubiertos de plástico	28,0	16,5	2,5	9,5	100
22 01 160	015024	160					30,0	18,0	3,0	9,5	140
22 02 140	043430	140		negro atramentado	pulida	con fundas en dos componentes	28,0	16,5	2,5	9,5	129
22 02 160	023173	160					30,0	18,0	3,0	9,5	170
22 05 140	042891	140		cromado		con fundas en dos componentes	28,0	16,5	2,5	9,5	127
22 05 160	077275	160					30,0	18,0	3,0	9,5	169
22 06 160	033790	160		cromado		aislados con fundas en dos componentes, según norma VDE	30,0	18,0	3,0	9,5	175

Alicates de montaje

DIN ISO 5743

28

- > Especialmente adecuada para trabajos de sujeción y ensamblaje con fuerza de presión aumentada
- > Superficie de agarre rayada
- > Acero especial para herramientas, forjado y templado al aceite

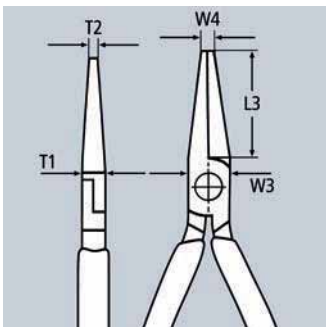
28 01 200
 28 21 200

Núm. de artículo	EAN 4003773-	↔ mm		Alicate	Cabeza	Mangos	Dimensiones					
							L3 mm	W3 mm	T1 mm	W4 mm	T2 mm	g
28 01 200	044468	200		negro atramentado	pulida	recubiertos de plástico	33,0	13,5	10,5	4,0	10,5	197
28 21 200	028246	200		negro atramentado	pulida	recubiertos de plástico	34,0	13,5	10,5	3,0	3,0	187